

1" Metallic Models

EXP SERIES PUMPS

ARO® EXP 1" metallic diaphragm pumps achieve flow rates of up to 52.2 GPM (197.6 LPM) and offer a wide array of material and porting configurations. These pumps are often used for transfer, filling, recirculation and batching in ceramic, industrial, chemical and petrochemical markets.

UPGRADE
PUMP FOR REMOTE
ACTUATION CAPABILITY

Ratio:	1:1
Maximum GPM (LPM):	52 (197)
Displacement per cycle Gallons (Liters):	0.232 (0.88)
Air Inlet (Female):	1/4 - 18 N.P.T.
Fluid Inlet/Outlet:	1 - 11-1/2 N.P.T.F.-1, Rp1(1-11 BSP)
Max. operating pressure psi (bar):	120 (8.3)
Suspended solids max. dia. in. (mm):	1/8" (3.3)
Weight lbs (kg):	PX10R-XAX-XXX 20.7 (9.4)
	PX10R-XCX-XXX 35.2 (16.0)
	PX10R-XHX-XXX 39.6 (18.0)
	PX10R-XSX-XXX 38.2 (17.3)
	Note: Add 4.65 lbs (2.11 kg) for aluminum air motor
	Add 11.09 lbs (5.03 kg) for stainless steel air motor
Maximum dry suction lift ft(m):	19 (5.7)
Sound Level:	70 PSI 60 Cycles/Min 80.6 db(A)
Muffler Included:	93110



Ordering

Position	1	2		3	4	5		6	7	8		9	10
Example:	PX10	X	-	X	X	X	-	X	X	X	-	X	X

Position 1 Model Series	Position 2 Center Section	Position 3 Connections	Position 4 Wetted Parts	Position 5 Hardware	Position 6 Seat Material	Position 7 Ball Material	Position 8 Diaphragm Material	Position 9
PD10- Standard Pump PE10 - Electronic Interface Accessible Pump	A - Aluminum* R - Polypropylene S - Stainless Steel*	A - NPTF Thread B - BSP Thread	A - Aluminum* C - Cast Iron H - Hastelloy-C* S - Stainless Steel*	P - Plated Steel S - SS	A - Santoprene® C - Hytrel® E - Carbon Steel F - Aluminum G - Nitrile H - 440 SS L - Hastelloy-C S - 316 SS	A - Santoprene® C - Hytrel® G - Nitrile S - 316 SS T - PTFE V - Viton®	A - Santoprene® C - Hytrel® G - Buna-N L - Long-Life PTFE M - Medical Grade Santoprene® T - PTFE/Santoprene® V - Viton®	Fluid control options for pump with electroic interface (PE10 model). See complete description on page 35

* Acceptable for use in hazardous locations. - NEC / CEC: Class I&II, Div 1&2, Group A-D
- ATEX: Zone 1&2, 21&22

Hytrel® and Viton® are registered trademarks of the DuPont company. Santoprene® is a registered trademark of Monsanto Company, licensed to Advanced Elastomer Systems, L.P.

Accessories

- Air Line Connection Kit | 66073-2
(Piggyback Filter/Regulator with gauge, pipe nipple and 5-foot air hose)
- Diaphragm Failure Detection | 67237
- Cycle Counter Kit | 66350
- Cycle Sensor Kit | 67350 (PE10X pump model is required)
- Service Repair Kits | 637397 (air motor for PX10A, PX10R and PX10S),
637401-XX (fluid section)
637395-X (major air valve assembly)

1" Metallic Dimensions and Flow Charts

DIMENSIONS

- | | | |
|--------------------------|-------------------------|-------------------------|
| A - 12-11/32" (313.2 mm) | G - 12-7/16" (315.9 mm) | N - see below |
| B - 11-9/16" (293.7 mm) | H - 6-1/4" (158.8 mm) | P - 5-27/32" (148.2 mm) |
| C - 4" (101.6 mm) | J - 7-5/16" (185.7 mm) | Q - 12" (304.8 mm) |
| D - 1-1/4" (31.8 mm) | K - 13/32" (10.3 mm) | R - see below |
| E - see below | L - 1-1/2" (38.1 mm) | |
| F - see below | M - 6-15/32" (164.3 mm) | |

- | | | | |
|---------------|---------------------|-----------------------|-------------------------|
| PX10A-XXX-XXX | "E" ----- | "F" 8-1/8" (206.4 mm) | "R" 14-1/32" (356.2 mm) |
| PX10R-XXX-XXX | 11-1/32" (279.5 mm) | 8-5/16" (211.1 mm) | ----- |
| PX10S-XXX-XXX | ----- | 8-3/16" (207.9 mm) | 13-27/32" (351.4 mm) |

- | | |
|---------------|----------------|
| | "N" |
| PX10X-XAX-XXX | 1/4" (6.4 mm) |
| PX10X-XCX-XXX | 9/32" (7.1 mm) |
| PX10X-XHX-XXX | 9/32" (7.1 mm) |
| PX10X-XSX-XXX | 9/32" (7.1 mm) |

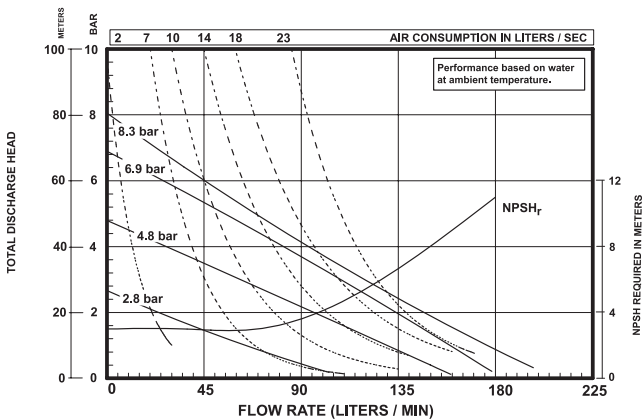
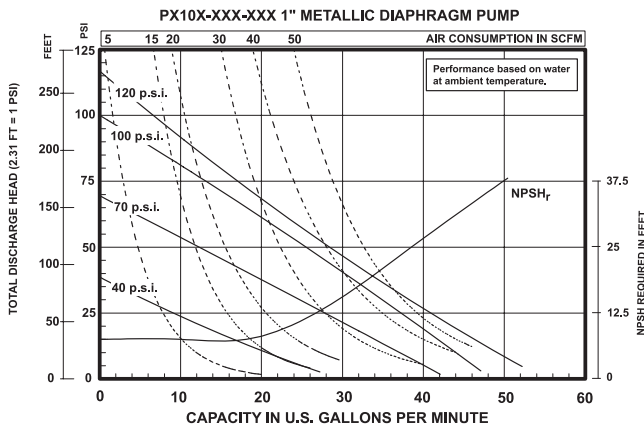
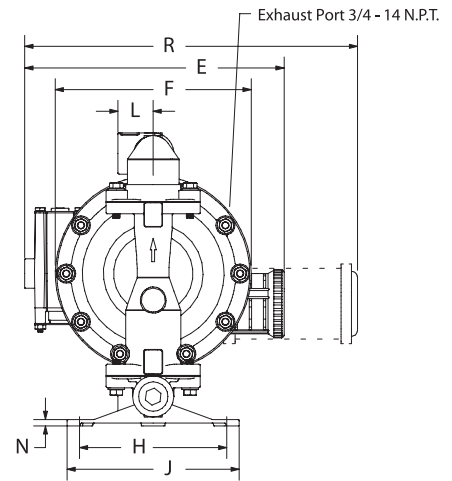
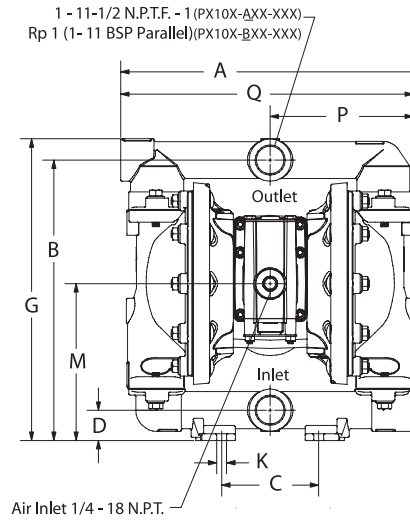

Refer to www.AROzone.com for full size flow curves.
For additional information contact
technical support at 1.800.495.0276

Ordering Position 10

Specialty Code 1 (Blank if no Specialty Code)

- | | |
|---------------------|--|
| A - Solenoid 120VAC | G - Solenoid 12VDC ATEX/IECex* |
| B - Solenoid 12VDC | H - Solenoid 24VDC ATEX/IECex* |
| C - Solenoid 240VAC | J - 120VAC NEC/CEC* |
| D - Solenoid 24VDC | K - Solenoid 220VAC ATEX/IECex* |
| E - 12vDC NEC/CEC* | N - Solenoid with no coil |
| F - 24vDC NEC/CEC* | O - Standard Valve Block (No Solenoid) |
| | P - Ported Motor (No major valve provided) |

Ordering Position 11

Specialty Code 2 (Blank if no Specialty Code)

- | | |
|--|--|
| E - End of stroke feedback + Leak Detection | L - Leak Detection |
| F - End of stroke feedback | M - Leak Detection ATEX/IECex/NEC/CEC* |
| G - End of Stroke ATEX/IECex* | O - No Option |
| H - End of Stroke/Leak Detection ATEX/IECex* | R - End of Stroke Feedback NEC / CEC* |
| | T - End of Stroke Feedback + Leak Detection NEC / CEC* |

* Acceptable for use in hazardous locations. - NEC / CEC: Class I&II, Div 1&2, Group A-D
- ATEX: Zone 1&2, 21&22