

# INOX60

## BIANCO STAINLESS STEEL JET PUMP WITH ELECTRONIC PUMP CONTROLLER

The pump is a self-priming surface mounted pressure system and has a suction capability of up to 8m. Used for supplying water to domestic installations and applications where a suction lift is required.

### FEATURES:

- The new nXt intelligent electronic pump control is fitted and wired to the pump with plug and play leads for automatic starting, stopping and restarting after power loss or water loss
- Run dry protection to prevent pump damage
- The nXt controller has an in-built check valve to prevent water back-flow through the pump
- Corrosion resistant pump body, diffuser and impeller to ensure pump durability
- 240V single phase TEFC motor with in-built auto reset thermal overload to prevent pump from damage
- A pressure tank is recommended

### MATERIALS IN CONTACT WITH DRINKING WATER PUMP

Pump Body:	Stainless Steel 304
Impeller:	Glass reinforced Noryl
Jet, Venturi, Diffuser:	Glass reinforced Noryl
Mechanical Seal:	Carbon Ceramic Nitrile
O Rings:	Nitrile

### CONTROLLER

Controller Body:	Glass reinforced Noryl
Diaphragm:	Butyl (TPV)
Ports, NRV:	Glass reinforced Noryl
Spring:	Stainless Steel
Pressure Sensor:	Brass OT58

### PACKAGE INFO

Weight:	11kg
Carton Dimensions:	420mm L x 230mm W x 460mm H

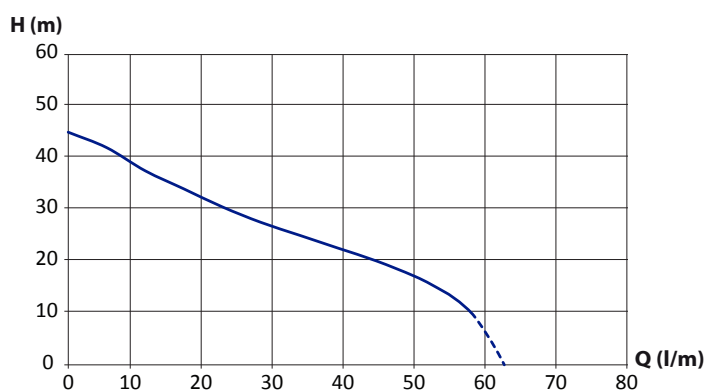

BIA-INOX60S2NXT

### ✓ SPECIFICATIONS

- Max head (m): 45
- Max flow (lpm): 58
- Taps: 5 (Medium homes)
- Power: 0.45kw (0.8hp)
- Ports: 25mm x 25mm (1"x1") BSP
- Start Pressure (bar): 2.2
- Volts: 240

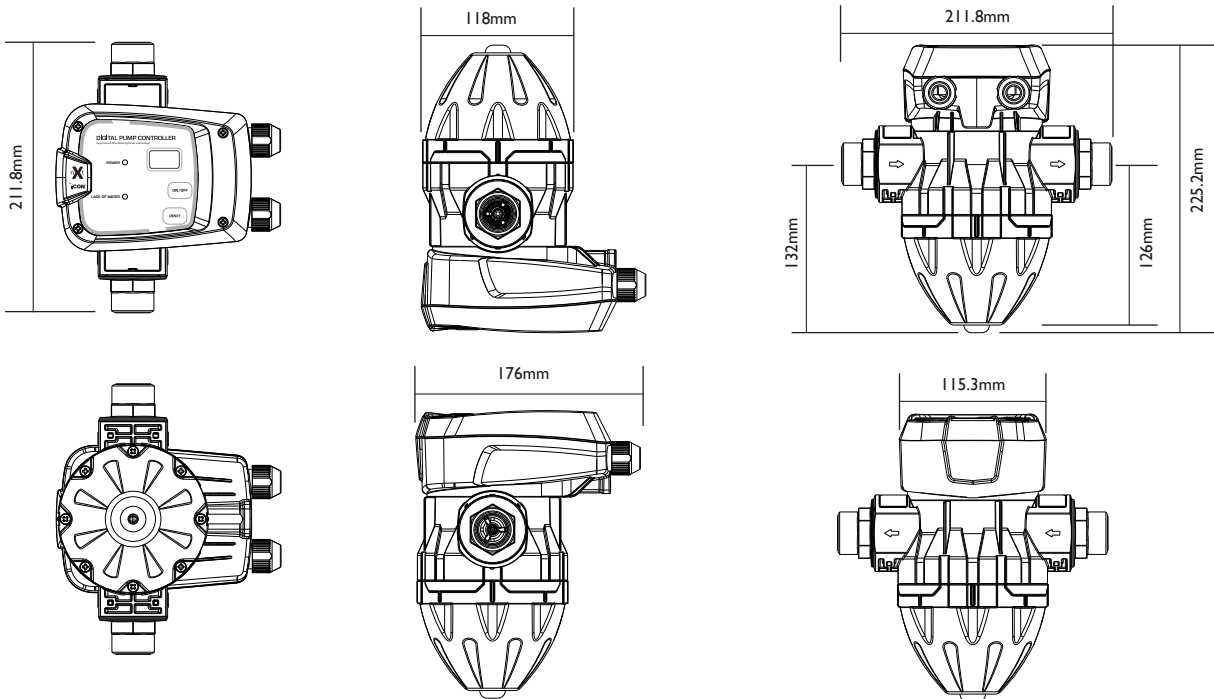

### The nXt series of pump controls represents the next step in pressurised pump control.

Designed and tested in Australia to ensure operation in the toughest of environments, combining innovative technology with robust proven architecture to guarantee constant supply of pressurised water when and where you need it the most.

Ideal for pumps supplying clean, non-volatile liquids without fibers or solids in applications such as:

- Household water supply
- Irrigation
- Water transfer
- Washing systems
- Pressure boosting

### Features:

- Digital display gives you a real time indication of system pressure
- Built in protection to prevent the motor from starting and stopping too often
- Dry run protection with auto restart function that tests for water availability every 24hrs
- Anti-seize function if pump has not operated for some time
- Controller automatically restarts pump after a power failure
- Easy assembly and removal using push-n-connect fitting with U clip
- Complies to AS/NZ 4020 drinking water standard
- Auto restart function when dry run occurs
- Over pressure protection
- Overload protection

	NXT
Function	ON/OFF
Modes	1
Size	1.5Kw
Rated Voltage	220-240V AC
Max Amps	10
Rated Power	1500w
Rating	IP65
Union Size	1"
Start Pressure	2.2 bar (32PSi)
Stop Pressure	on no flow
Max Pressure	10 bar (145PSI)
Max Liquid Temp	40°C
Cable to Pump	Plug and Play
Flylead for Pump	When sold as control only
Power Cable	10AMP
Communication	-
Accessories (Sold Separately)	-
	1 1/4" Union Kit

